

After taking everything out of the carry bag, center one person on each side, in line with center scissors beam. Grasp the lower "V" at the center. Both will lift and pull out, stepping away from each other.

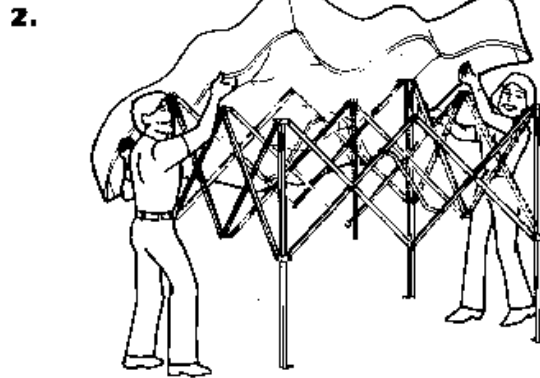

Pull frame out half way. Place fabric top on framework.

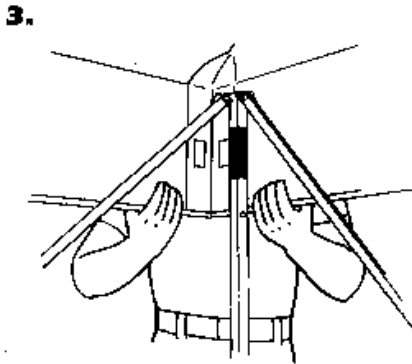

Attach to each velcro corner.

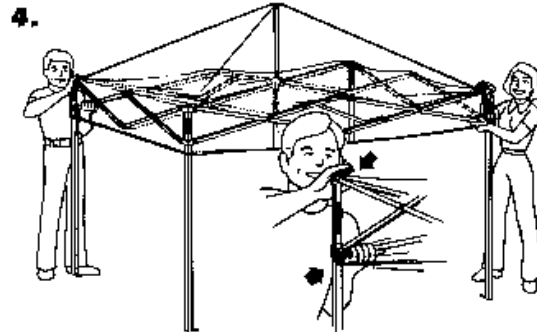

Pull frame completely out. Push the leg socket over the button, so that it is resting on top of the button. Do this to each leg in the up, or extended position.

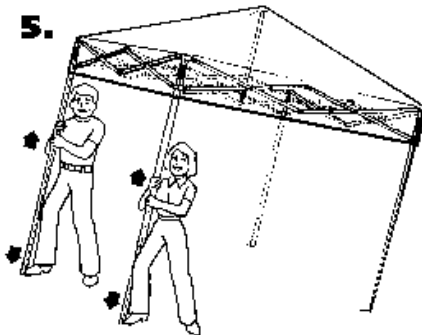

Lift each leg and slide lower leg extension out until the latching button snaps into the first adjustment hole. The KD Kanopy will be set at the lowest upright position.

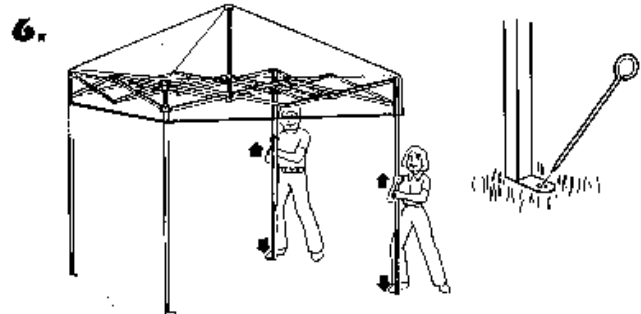
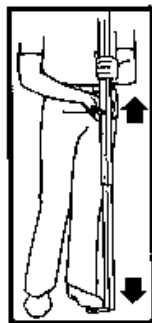

For height or leveling adjustment, depress leg latching buttons and slide the lower leg extensions, as required, to latch at any of the four adjustment holes. Last, put the four ground spikes through each hole in the bottom of the legs

TAKE - DOWN

Fully retract all lower leg extensions. Depress latching buttons at sliding leg sockets and move sockets below the latching button. Push frame together half way. Two persons centered on opposite side, inline with center scissors beam, will grasp the upper inverted "V" at the center. Both will lift and push in, walking toward each other.

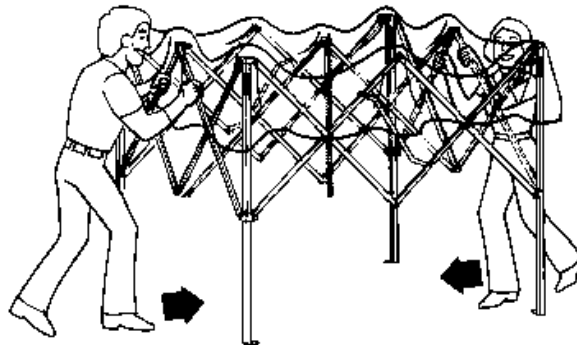

TOP FOLDING INSTRUCTIONS

CAUTION:

Please use care when folding combination light and dark colored tops. Fabric Dyes have a tendency to migrate from dark shades to lighter shades if the wetted sides are in contact when folded and stored.

1. Fold all four corners together and lay flat. This is the most important step in correctly folding Color Combination tops. Keeping the coated sides of the same color together to prevent color transfer.
2. Take the four corners and fold them to the opposite side.
3. Fold the top of the top down to the bottom edge.
4. Fold in half lengthwise bringing the top to the bottom edge.
5. Fold into thirds and place in top bag.

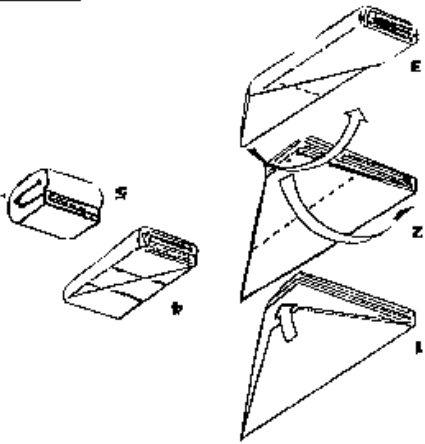

USING THE KD CARRY BAG

1.

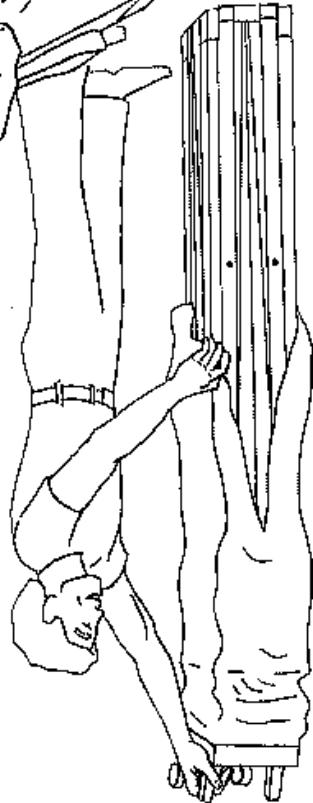

2.

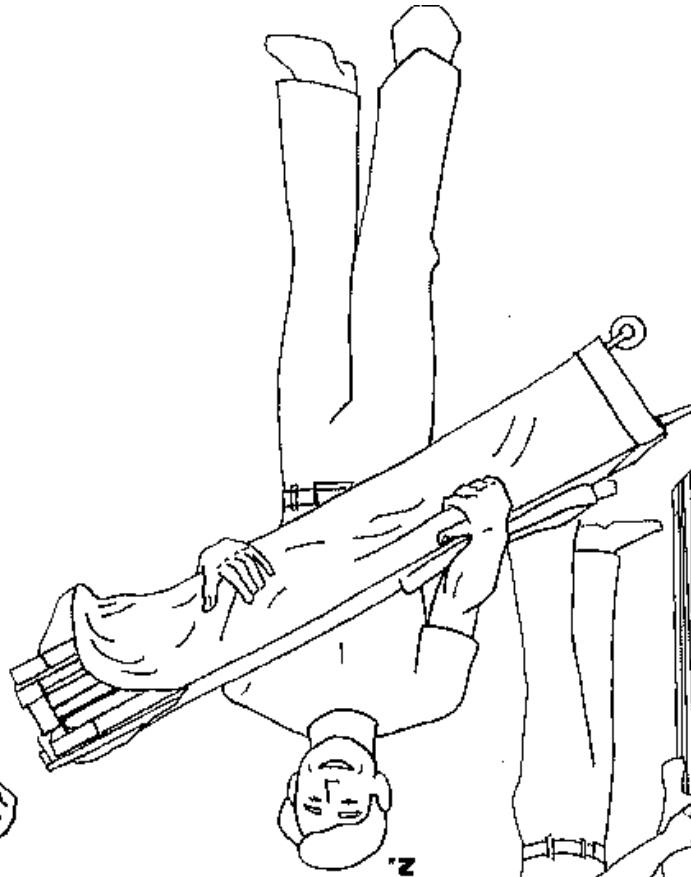

3.

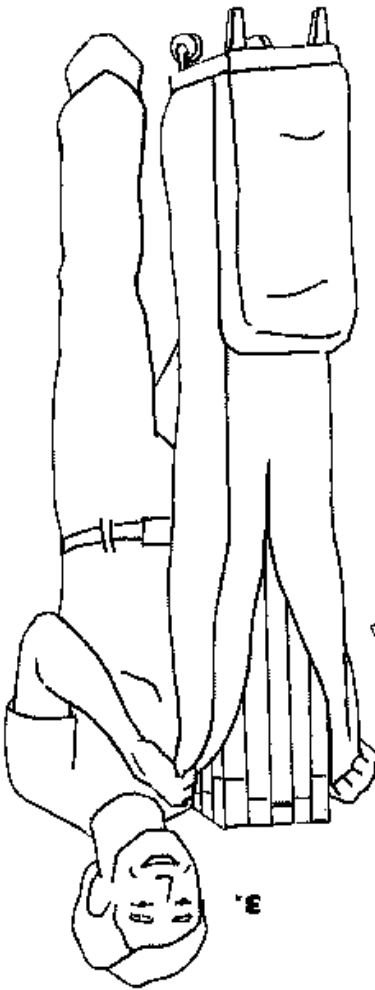

Stand the carry frame upright and open carry bag to full length, by unfastening the hook & loop closures. 1] Slip the bag over the top end of the canopy frame. Pull the carry bag until it completely covers the canopy frame. Place the canopy top in the attached bag. 2] Use proper lifting technique to turn the canopy frame rightside up. 3] Fasten the hook & loop closures and wheel your KD unit away with ease!

Wheel bag is shown below. Please follow these same instructions for non-wheel bags.

KD SIDE PANEL SET-UP

1.

Unfold side panel(s) and wrap the four hook and loop straps around the bottom scissor bars and hook them back on themselves. One at each corner and two in the middle.

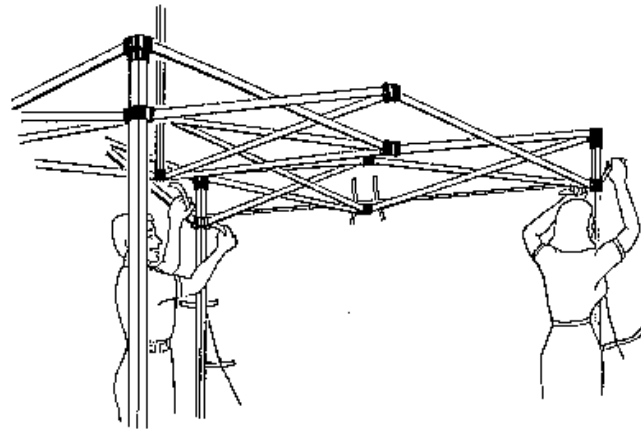

2.

Wrap the 6 hook and loop straps on each side of the side panel around the canopy leg and hook them back on themselves.

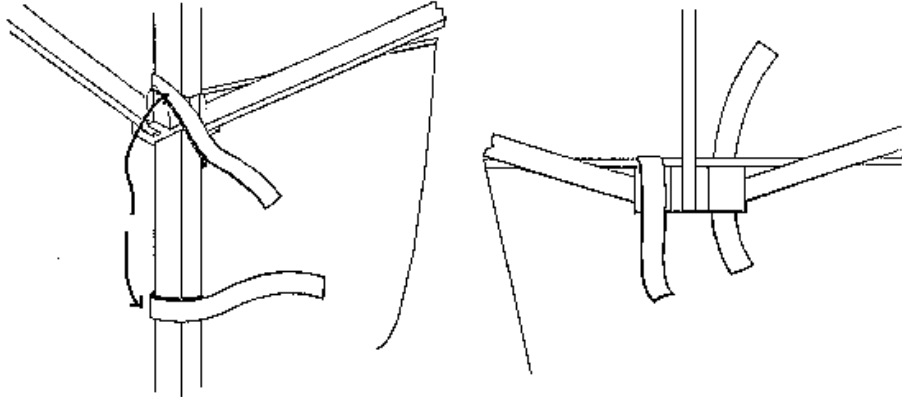

RAIL CURTAIN SET-UP

1.

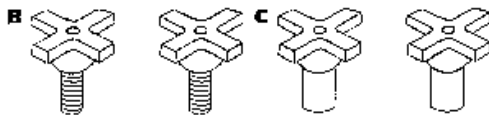
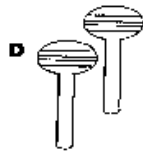
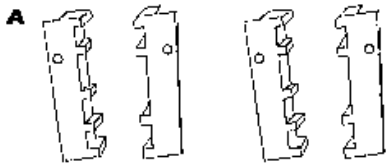

Check to be sure that you have the following parts:
Two bracket sets: (A) 4 dynidom bracket pieces, (B) 2 male,
(C) 2 female screws, (D) thumb screw, (E) male pole,
(F) female pole and (G) rail curtain (not pictured).

2.

Insert male adjustable screw into the bracket pieces.

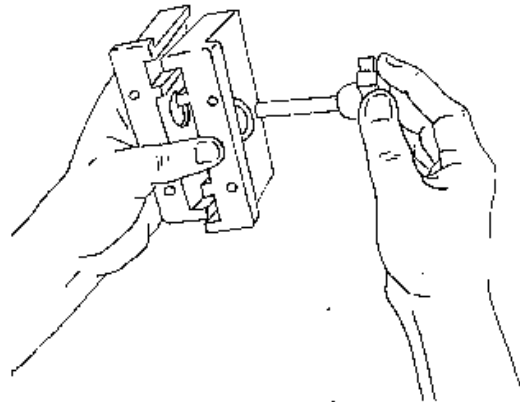

3.

Connect the brackets by tightening the female adjustable screw into the male screw.

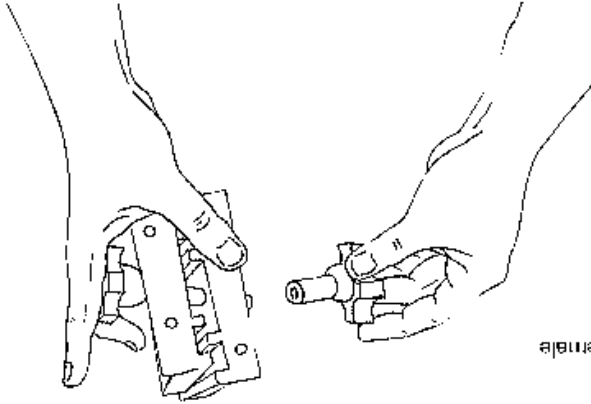

4.

Insert male rail piece into the female rail piece. Lock into place with push pin.

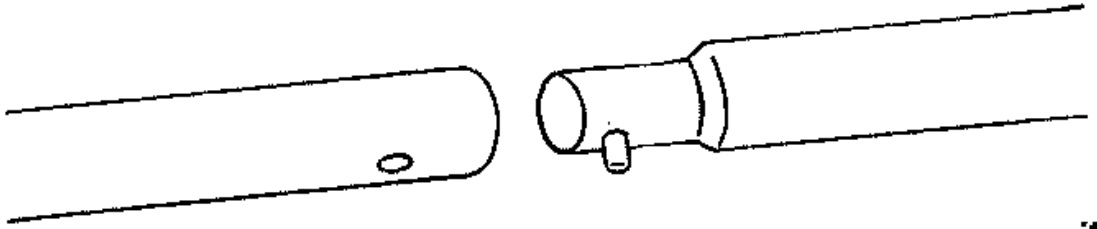

5.

Slide rail pole into sleeve of rail curtain.

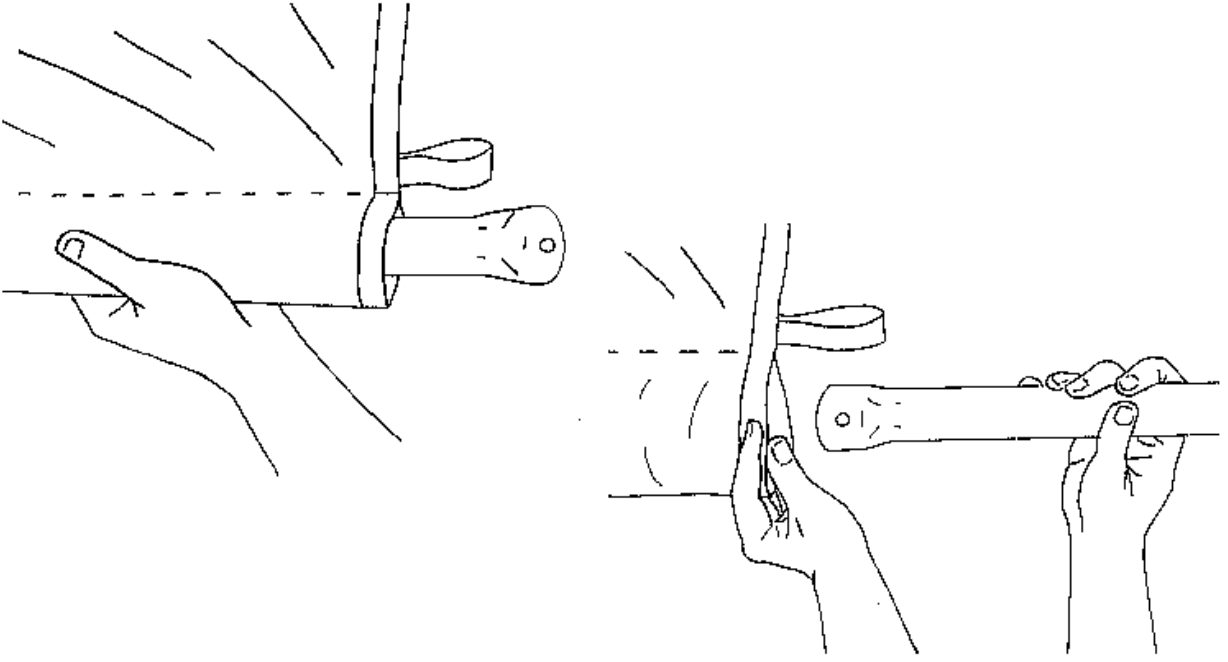

RAIL CURTAIN continued...

6.

Adjust your KD Kanopy unit to the desired height using the push pins on each leg. Next Position the assembled brackets at a 45 degree angle on the leg of the unit. Tighten the bracket screws to the unit leg, make sure to rest the bracket on the push pin.

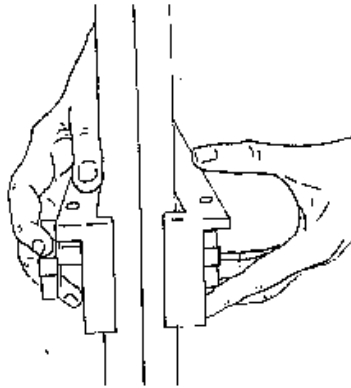

7.

Place rail curtain over one of the holes on the bracket. Insert the given thumb screw to secure the rail curtain into the bracket.

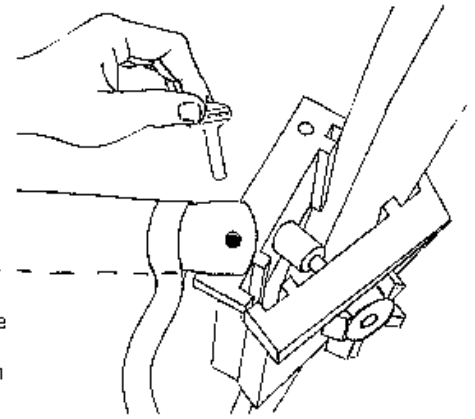

8.

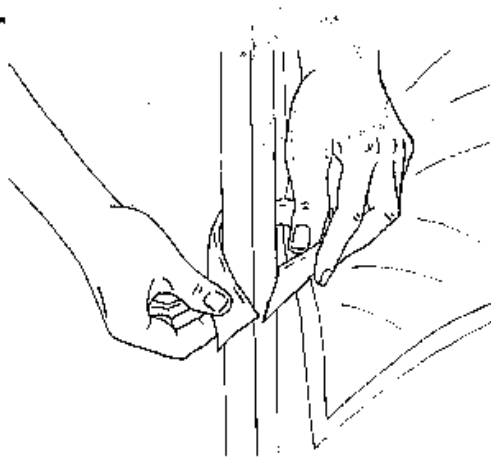

Last, fasten the rail curtain to the unit by using the attached hook & loop closures.

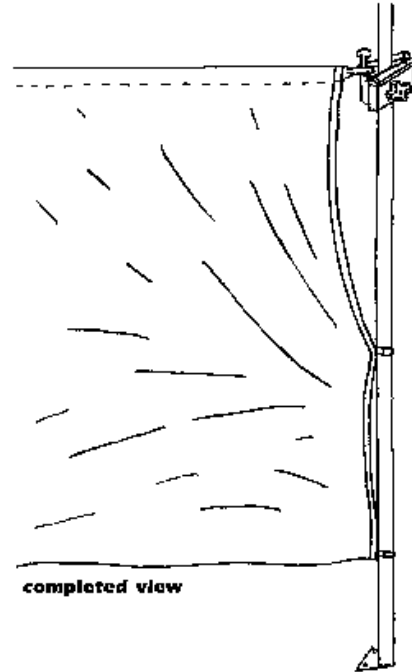

KD Kanopy

The Best Under the Sun®

OKD KANOPY, INC.

3755 West 69th Place

Westminster, CO 80030

303.650.1310

Fax: 303.650.6093

CALL TO ORDER

1-800-432-4435

www.kdkanopy.com

If you have any difficulty at all
please contact us.

8022103